



CAJA G.456

ALGUNAS POSIBILIDADES DE USO:

- * Acarreadores.
- * Elevadores de granos con chamiquera.
- * Transmisiones.

	9,5
	SAE 90

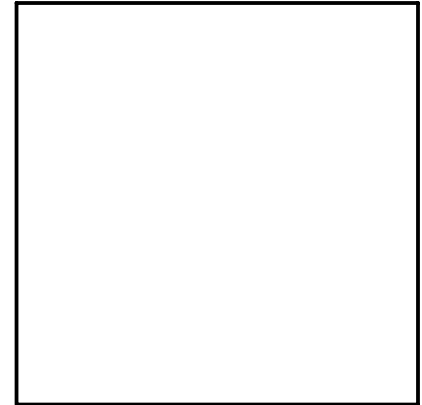

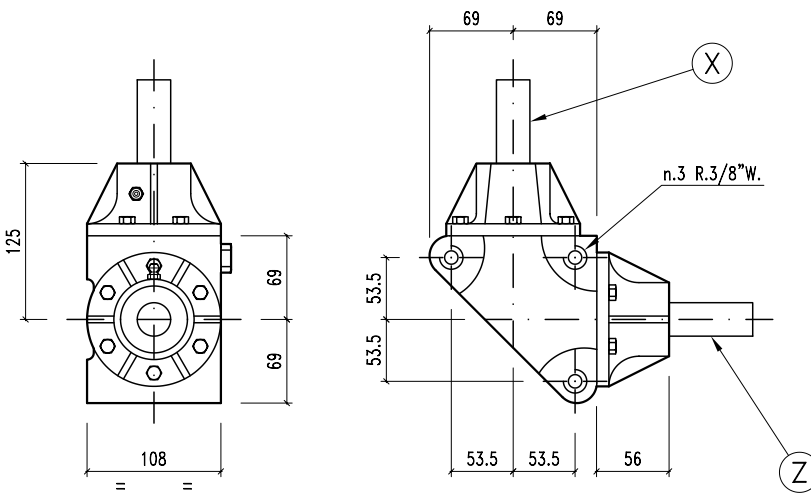

9



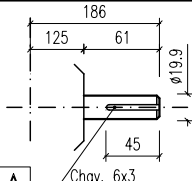



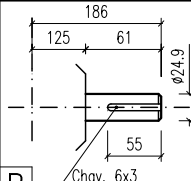

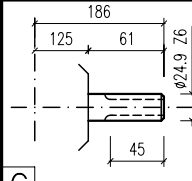

A



B

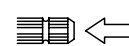

C

i	r.p.m.	HP	KW	    			 					
				ARMADO	ENTRADA	CODIGO	CODIGO					
1:1	540	10	7,36	X	Y	Z	9	X-Z	9	181		
1:1	540	15	11,03	B		B	9	X-Z	9	168		
1:1	540	15	11,03	B		C	9	X-Z	9	152		
1:1	540	15	11,03	C		B	9	X-Z	9	319		
1:1	540	15	11,03	C		C	9	X-Z	9	320		

