



COMPANY WALTERSCHEID	DATE 12-12-2006	CODE 001183-B	DESIGNATION L.G.1052
-------------------------	--------------------	------------------	-------------------------

NOTES:

*Ratio between z and x - 1:1.210

*Ratio between z and y - 1:0.507

- ① Gear teeth number between z and w
- ② Gear teeth number between w and x
- ③ Gear teeth number between w and y

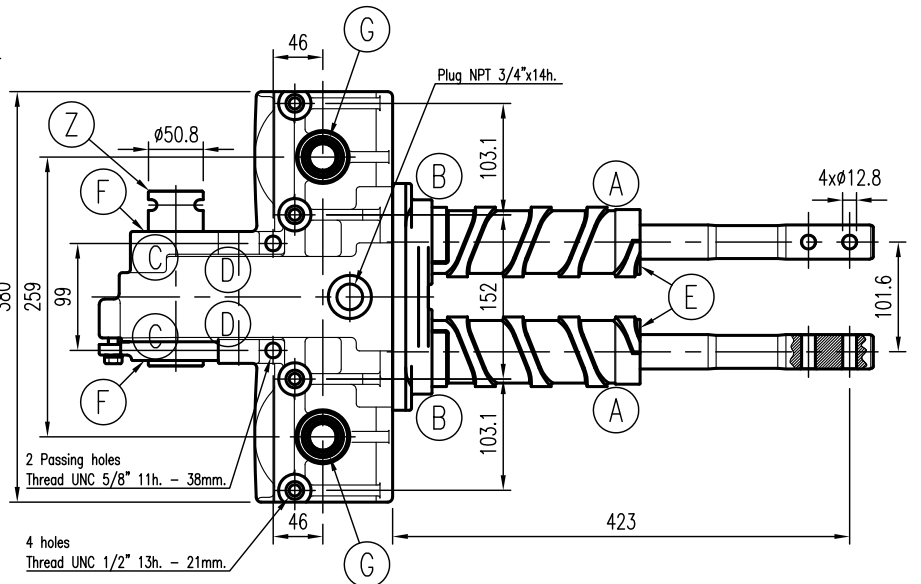
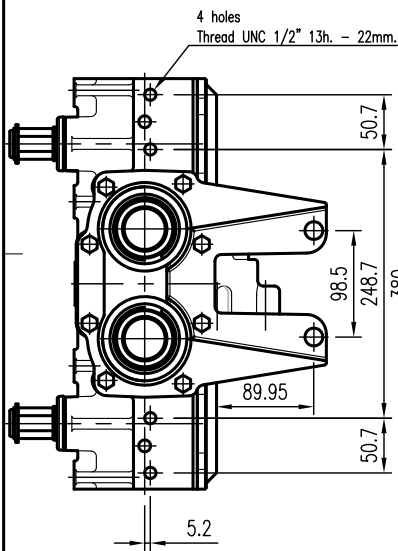
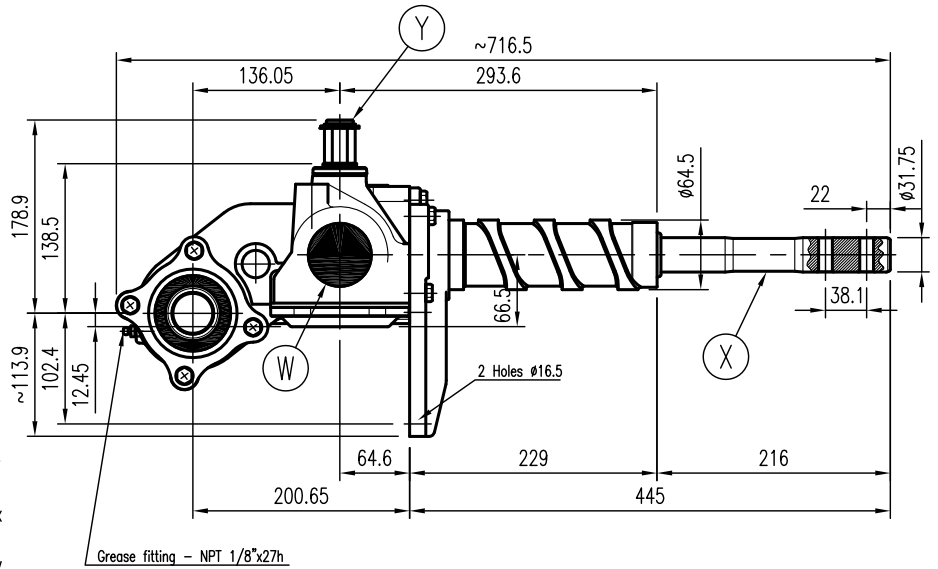

Row unit gearbox	Ratio	Rated input r.p.m.	Rated input power HP	Rated input power KW	Rated output torque da Nm (X)	Rated output torque da Nm (Y)	Weight Kg	Lubricant		Qty.								
	*	700	60	44.1	49.7	118.6	45	Oil	Grease	Kgs.								
								X		NGLI #0								
		Gear arrangement				Bevel couplings				Cylindrical couplings				Bearings				
		Helicoidal	Straight	Teeth number				Module	Helicoidal	Straight	Teeth number				Module	A	BHA 2020 Z0	
				Z1	Z2	Z3	*				M	Z1	Z2	Z3		*	M	B
				X	23	17	②	4.1			X	17	17	19	①	4.23	C	YB 3216 MF3
				X	17	30	③	3.4									D	BHA 1612 Z0
	Components material														Seals			
	Housing and spindle	Shaft W	Shaft X	Shaft Y	Shaft Z	Gears		E	31.75x52.15x15.6									
Nodular cast iron	Steel S.A.E 1045 Tempered	Steel S.A.E 4140 Tempered	Steel S.A.E 4140 Tempered	Steel S.A.E 8620 Case hardened	Steel S.A.E 8620 Case hardened		F	50.8x69.88x12.5										
							G	28.5x38x7.2										

GARRO FABRIL reserves the right to make any change to this product without prior public acknowledgement