



# CAJA M.128-30

## ALGUNAS POSIBILIDADES DE USO:

- \* Cintas transportadoras.
- \* Carros tolva.



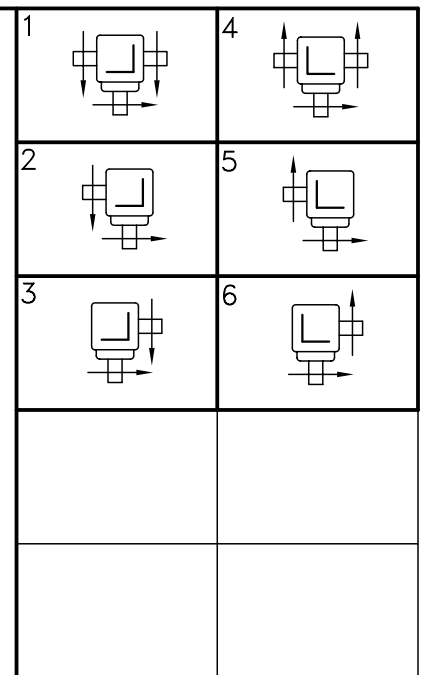
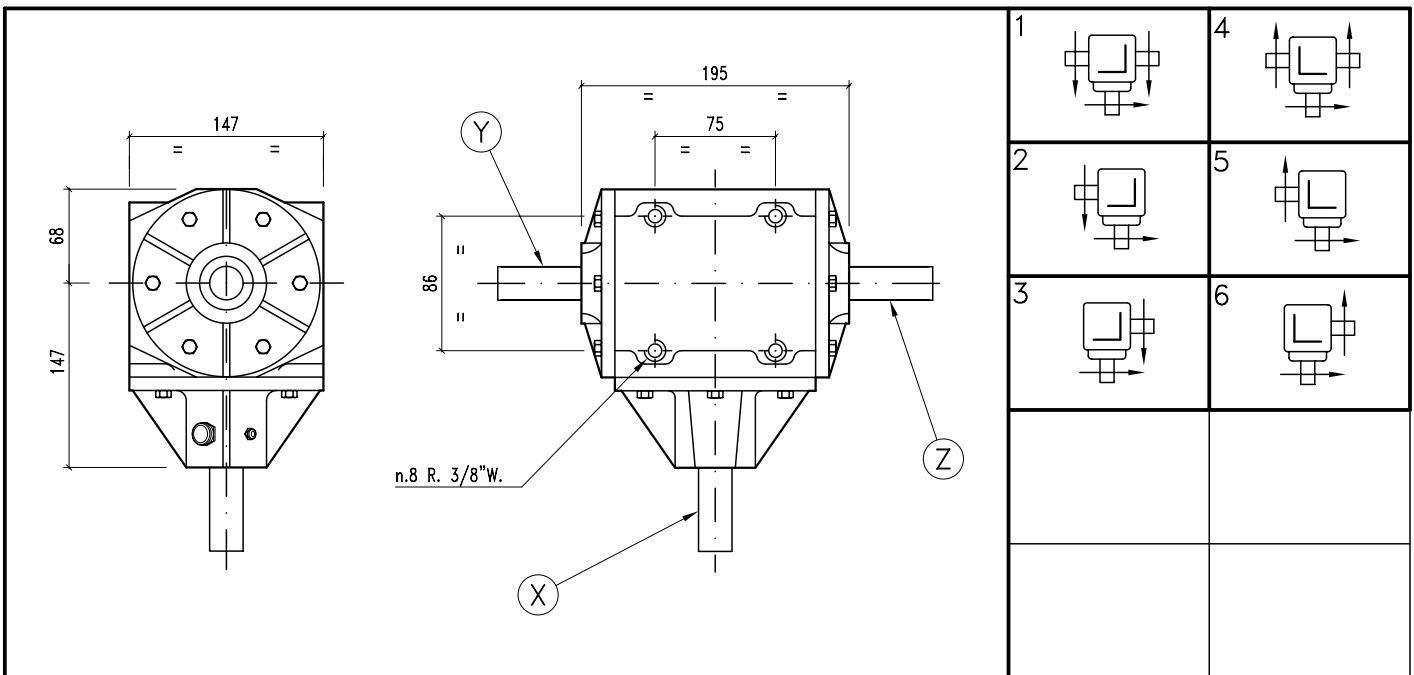
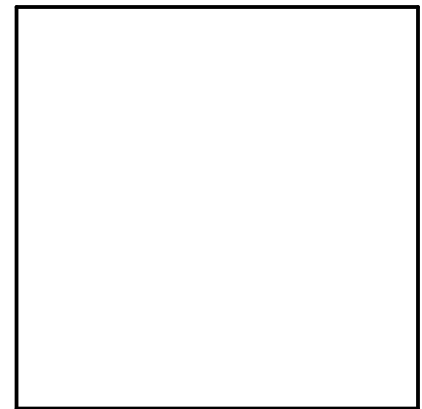

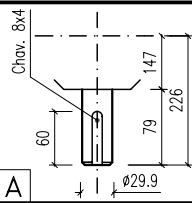
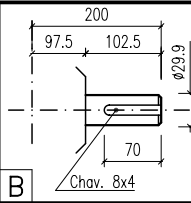
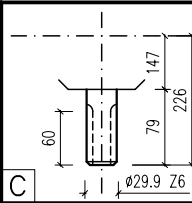
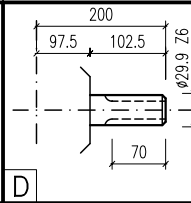





	17
	SAE 90



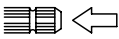

# CAJA M.128-30

	 r.p.m.	 HP	 KW	 X	 Y	 Z	 ARMADO	 ENTRADA		 CODIGO		 CODIGO
1:1	540	20	14,71	A	B	B	1-4	X-Y-Z	1	15-A	4	15-B
1:1	540	20	14,71	C	B	B	1-4	X-Y-Z	1	16-A	4	16-B
1:1	540	20	14,71	A	B		2-5	X-Y	2	17-A	5	18-B
1:1	540	20	14,71	A		B	3-6	X-Z	3	18-A	6	17-B
1:1	540	20	14,71	A	D	B	1-4	X-Y-Z	1	223-A	4	225-B
1:1	540	20	14,71	A	D	D	1-4	X-Y-Z	1	224-A	4	224-B
1:1	540	20	14,71	A	B	D	1-4	X-Y-Z	1	225-A	4	223-B
1:1	540	20	14,71	C	D	B	1-4	X-Y-Z	1	226-A	4	228-B
1:1	540	20	14,71	C	D	D	1-4	X-Y-Z	1	227-A	4	227-B
1:1	540	20	14,71	C	B	D	1-4	X-Y-Z	1	228-A	4	226-B
1:1	540	20	14,71	A	D		2-5	X-Y	2	229-A	5	230-B
1:1	540	20	14,71	A		D	3-6	X-Z	3	230-A	6	229-B
1:1	540	20	14,71	C	B		2-5	X-Y	2	232-A	5	231-B
1:1	540	20	14,71	C		B	3-6	X-Z	3	231-A	6	232-B
1:1	540	20	14,71	C	D		2-5	X-Y	2	234-A	5	233-B
1:1	540	20	14,71	C		D	3-6	X-Z	3	233-A	6	234-B



 <b>GARRO FABRIL S.A.</b>							